

INSTRUCTION MANUAL

WARE WASHING EM-LV50-SP



To ensure proper use of this appliance and your safety, please read the following instructions completely before operating this appliance.

English – Original



Index

1. Installation instructions	3
1.1 Introduction	3
1.2 Advantages	3
1.2.1 Legal provisions / Requirements	3
1.3 Installation	4
1.3.1 Installation suggestions	4
1.4 Connection to the water supply	4
1.4.1 Drainage connection	4
1.5 Electrical Network connection	4
1.5.1 Protective duct connection and voltage compensation	4
2. Operating instructions	5
2.1 Technical data	5
2.2 Instructions for the dishwasher's regular operation	5
2.3 Preparation of dishes for washing	5
2.4 Filling of basket	5
2.5 Manual filling of detergent	5
2.6 Rinse-aid dozer	5
2.7 Starting the washing program - Filling the boiler	6
2.8 Safety provisions	6
2.8.1 Further significant indications / Safety indications	7
2.8.2 Daily works	7
2.9 Maintenance / Care / Repair	7
2.9.1 Unloading dishwasher (dispenser)	7
2.9.2 Regular maintenance and cleaning works	8
2.10 Customer service	8
2.11 Spare parts, Accessories and Components	8
2.12 Troubleshooting	9
Ratings and expectations	10
Electrical diagram	11
Exploded view and spare parts list	12
Standards and directives	15
Packaging and device disposal	15



1. INSTALLATION INSTRUCTIONS

1.1 INTRODUCTION

This appliance complies with the needs of modern and professional cooking.

Please read these instructions carefully before operating this appliance.

In this manual you will find all significant safety indications, as well as other essential information needed for the regular start-up - and operation itself - of the appliance.

The person undertaking, on behalf of the user, the installation, start-up, maintenance and repair of the dishwasher, should be familiar with the operating instructions or trained by our customer service department. This is the only way to ensure the correct operation of the appliance and to avoid extra repair expenses.

Keep these instructions in a safe place for future reference.

As a condition to any warranty service obligation, the client must complete and send the Warranty Certificate to our company within 10 days of purchase date.

1.2 ADVANTAGES

This dishwasher has the following advantages:

- is made of Stainless Steel 18/8 304
- is manufactured and tested for continuous operation.
- easy and simple cleaning
- no jamming during the door opening and closing: simple use
- perfect dish and glass washing
- less environmental pollution
- excellent and friendly service; all spare parts available
- reduced water consumption

1.2.1 LEGAL PROVISIONS / REQUIREMENTS

This equipment complies with the requirements of Directives 2006/95/EU "on Low Voltage" (LVD) and 2004/108/EU "on Electromagnetic Compatibility" (EMC) and carries the mark.

You can obtain a copy of the declaration of conformity from your supplier.

This product complies with the requirements of Directive 2002/95/EC OF THE EUROPEAN PARLIAMENT AND OF THE COUNCIL of 27 January 2003 on the restriction of the use of certain hazardous substances in electrical and electronic equipment and carries the following mark

Waste disposal

According to the Directive 2002/95/EC OF THE EUROPEAN PARLIAMENT AND OF THE COUNCIL of 27 January 2003 on the restriction of the use of certain hazardous substances in electrical and electronic equipment (AHHE), the products and their parts covered by this directive should not be disposed of with regular garbage but be returned to the point of sale or be transferred to a recycling centre for electrical and electronic appliances. For further information address to the local authorities.

Marking

The product carries the following marks:

Input voltage xxV

Required voltage frequency (e.g. 50Hz)

The marks and

The manufacturer is not responsible for any damage ensuing from faulty connection of the appliance.



1.3 Installation

This dishwasher is delivered with water inlet and outlet hoses.

According to its construction, the connection of the machine to water and power supply must be performed by an authorized and locally recognized installer by keeping the existing specifications. Before connecting the appliance, check that the connection data on the data plate (voltage and connected load) match the mains electricity supply.

1.3.1 Installation suggestions

- Open the package. Before setting up the appliance, check it for any externally visible damage due to transportation. If in any doubt, call for a specialist to check it (from the authorized local dealer who sold the appliance).
- Place the dishwasher at the installation area, close to the necessary water and power supply (the ground should be sufficiently stable).
- The appliance should be placed horizontally. Possible inclinations should be corrected using a spirit level.
- Following the successful installation, the dishwasher should be cleaned thoroughly with a conventional detergent before it is put into operation.

1.4 Connection to the water supply

ATTENTION: The connection with the water supply should be made according to the current safety standards.

The dishwasher may be connected only to a cold water supply.* (In case you want to connect it to a hot water supply, please contact our company)

- The water supply hose should have a flap valve (non-return valve) according to DIN 1988.
- The water supply hose/pipe should be rinsed before the appliance's connection.
- The water supply hose/pipe should have a minimum internal diameter of 16 mm and the connection with the hose should be 3/4 inch.
- All hose collars should be adjusted in a fixed position before the appliance is put into operation.

ATTENTION: The water pressure must be between 2 and 5 bar.

1.4.1 Drainage connection

The outflow is accomplished through gravity force (natural flow). The outlet hose should be connected either directly to the main drainage - where a pipette for odours is anticipated, or water runs directly to a drainage well in the ground, which has a pipette for odours.

ATTENTION: The outlet hose should not be placed higher than a level (as given for each appliance's type) from the lower side of the dishwasher's dispenser.

1.5 Electrical Network connection

ATTENTION : All electrical work must be carried out by a suitably qualified and competent person.

The dishwasher operates under specific voltage depending on the type of the dishwasher.

You should supply the power, depending on the appliance's power reception (the electrical connection should be made by authorized electricians). Specifications should be met according to the corresponding parts of DIN, VDE, D100, the EVU connection terms, the relevant ZH 1/37, chapter 7.2 - as well as the current specifications for accident prevention.

Respectively, the appliance must be connected to a direct power supply electrical installation through an H07 RN-F cable with load relief of the appliance.

1.5.1 Protective duct connection and voltage compensation

The electrical safety of this appliance is ensured only if the protective duct has been connected and checked properly. The corresponding specifications should be met at this point (see paragraph 1.5).

In addition, the appliance should include a voltage compensation system.

For this reason, the backside of the appliance has a screw with the indication "voltage compensation".

Following the electrical connection, the action of the protective duct, the voltage compensation and the insulation value should be checked according to the existing provisions of DIN VDE.



2. OPERATING INSTRUCTIONS

2.1 Technical data

You can find the technical data of each appliance at the adhesive label of the dishwasher.

2.2 Instructions for the dishwasher's regular operation

The appliance is exclusively used to clean dishes, cups, glasses, silverware, etc. following their use during lunches/dinners.

You should pay special attention that the items to be washed are suitably placed for dishwashing.

Silverware should be cleaned from food residues, if not washed right after lunch / dinner (colouring and spots from certain foodstuffs).

Do not wash in this appliance items which has been in contact with acids, mineral oil, grease, gasoline or colours and solvents (industrial chemicals).

2.3 Preparation of dishes for washing

Do not let food residues dry onto the dishes. In order to avoid filter blockage as well as the cleaning water to become dirty quickly, you should remove large food residues, olive pips, lemon peels, tooth picks, etc., before you place the dishes in the basket.

We recommend you to leave in water for a while or rinse the glassware that has food residues dried on.

2.4 Filling of basket

Put glasses, cups, large plates, etc. with the opening facing down in the anticipated baskets. Do not pile one on top of the other.

Glasses should not touch each other (damage in glass, stains due to contact).

Place cutlery in the appropriate basket made of synthetic material, with the handle facing down.

Silverware may be placed freely on the levelled plastic basket.

In any case, you should avoid overloading the basket.

Water supply hoses should remain free (not blocked or stretched).

2.5 Manual filling of detergent

The detergent to be used should be suitable for dishwashers. After the recommended operating temperature is accomplished, you may put the detergent directly into the dispenser.

If the dishwasher has an integrated detergent pump, we put the pump's elastic pipe indicated as DETERGENT in the detergent dispenser.

Use exclusively detergent with little foam effect.

We recommend that you use detergent and rinse aid from the same manufacturer.

ATTENTION: Do not use detergent for hand-wash.

The correct detergent dosage depends on the water hardness and the amount of dirt on the dishes. Follow the dosage information of the detergent's manufacturer.

Less detergent quantity affects negatively the washing result, while more detergent quantity does not present better results, but rather more consumption and environmental pollution.

2.6 Rinse-aid dozer

The dishwashers have an automatic rinse aid dozer. Put the elastic pipe indicated as «RINSE AID» in the storage compartment.

The dozer is adjusted from the manufacturer's premises at its maximum value and may be adjusted accordingly - depending on water hardness, how dirty the dishes are, and the detergent used - following the successful installation of the dishwasher.

Turning the adjustment screw clockwise, the flow is reduced (-), turning it counter-clockwise the flow is increased (+). We recommend that you let the constructor to adjust it (or the specialized personnel of the authorized local dealer who sold the appliance).

Before you perform these works, you should turn off the switch of the appliance or turn off the corresponding switches so that no current flows, or turn off the power supply switch.

INDICATION: The dozer should not operate while dry, since it will lose its suction properties. It is necessary that you have filled the storage compartment before the appliance's installation, so that the dozer operates correctly during the first wash.



Do not use caustic products. If you do not follow this indication, you will not be covered by the guarantee.

2.7 Starting the washing program - Filling the boiler

- Check that the suction filter, in the tank, has been placed in the correct position.
- Check that the overflow hose is inserted correctly in its inlet.
- Make the connection with water supply and drainage according to the instructions.
- Push ON-OFF switch (No.1) (or turn to the position POWER).
- The dishwasher is automatically filled with water up to the set water level.
- The indicator lights on (NO.4) showing us that the boiler's heating has started.
- When the water of the boiler is heated, the corresponding LED lights off (NO.4) and a new LED lights on (NO.5) showing us that the water in the dispenser is heating up.

Note 1 : At the model 35 (basket 35 x 35) the indicator No. 4 continues to light on while the boiler is heating.

- When this LED lights off, then the dishwasher is ready for wash.
- Open the door. Insert the basket with the items (dishes, glasses, etc.). Before inserting the basket with the items, be sure that all food residues have been removed.
- Add the liquid detergent manually in the dispenser, unless the dishwasher has a detergent pump. Check the level of the rinse aid and detergent storage compartment.
- In order for the washing program to start, push the START button (Button No. 2). At the model 1500 (Hood type) the washing program starts closing the door.
- The washing program, lasting 2 min., starts automatically, while at the same time the LED NO.6 of the program's start lights on, washing and rinsing the items inserted.

Note 2 : If the door does not close properly, the dishwasher does not function and the LED No. 7 lights on.

- When the washing program is finished, the program LED (NO.6) lights off. Open the door and remove the basket with the clean items.
- Let them dry.

If, following the wash, there are stains from dirt or water spots, the cause may be one of the following:

- Wrong quantity of detergent in respect of water.
- Rinsing water with high capacity of mineral elements.
- Insufficient quantity of rinse aid during rinsing.
- Wrong loading of the items in the basket.
- Low water pressure during rinsing.
- Low water temperature during washing.
- Filters are clogged or miss-positioned.

RECOMMENDATION: For a better result, especially with glasses, use water softener.

2.8 Safety arrangements

There is a safety adjustment at the door, which interrupts the appliance's operation during washing, if the door opens by mistake. There is thermal protection integrated in the pump motor winding with automatic start-up, which interrupts power supply to the pump, in case of overcharge.

There are thermal safety fuses, which interrupt the power supply in case of boiler or dispenser overheating.

2.8.1 Further significant indications / Safety indications

No technical modifications are allowed in this appliance. The manufacturer is not responsible for any possible damages resulting due to modifications.

The same applies in case that the appliance is used for any other purpose



except the one anticipated, in case of fault or improper use.

The water inside the dishwasher is not potable.

Use, maintenance and repair of dishwasher should be performed only by persons familiar with these works and informed for any possible risks.

2.8.2 Daily works

- Turn off the operation switch of the appliance S1.
- Turn off the main switch / fuses.
- Turn off water supply faucet.
- Empty the washing dispenser removing the overflow pipe after turning off the switch ON-OFF No. 1 to avoid overcharging the tank and causing damage to the dishwasher.
- If the dishwasher is equipped with draining pump, follow the above mentioned steps and then press the start button once in order to start the automatically 2 minutes draining program. (ATT: during the draining program the door must remain closed.)

2.9 Maintenance / Care / Repair

The perfect operation and safe use may be ensured only through the correct use of the appliance, as well as the compliance with the operation instructions, the corresponding specifications and the care and cleaning indications.

This applies both for the compliance of the provisions of law on appliance safety (GSG) and the existing specifications of ZH 1 and VBG on accident prevention.

RECOMMENDATION: Before cleaning or maintenance works, the appliance should not be connected with voltage through the installed main switch / fuse. The appliance should never be sprayed with water or high pressure cleaning aid, because any insertion of water in the electrical elements may affect the regular operation of the appliance as well as the protection against electrical shock (insulating protection).

We recommend that you prepare a relevant maintenance agreement for all maintenance and repair works with our company (or with a service team / workshop of an authorized local dealer who sold the appliance).

All works / repairs performed in this appliance must be reported on the last page of the operating instructions, along with the signature / company name.

Substantially, no safety arrangement should be put out of operation. If the disassembly of individual safety arrangements is required, e.g. for maintenance or repair works, the reassembly of the relevant safety arrangements should be performed immediately after the completion of works.

2.9.1 Unloading the water from the dishwasher's tank (dispenser)

- Turn OFF the power of the dishwasher
- Empty the washing dispenser removing the overflow hose.
- If the dishwasher is equipped with draining pump, follow the above mentioned steps and then press the start button once in order to start the automatically 2 minutes draining program. (ATT: during the draining program the door must remain closed.)
- Remove the filter and clean it carefully with water.
- Rinse the washing compartment to remove any dirt residues.

Then, reassemble the parts in reverse order. The appliance should never operate without a filter.

During non-operation, the door should remain half-open or completely open (in order to avoid odours).

2.9.2 Regular maintenance and cleaning works

Regularly, you should remove the rotating arms and sprinkler, clean them carefully with water and reposition the parts in reverse order. This work should be performed with great care.

PAY ATTENTION TO THE CORRECT POSITION OF FILTERS AND SPRINKLER!

Do not clean the sprinkler's injectors with tools or sharp objects.

You may clean the appliance with warm water and conventional cleaning aids. Rub with water and then let it dry. The stainless steel parts should be treated with special means for steel and you should never clean them with steel wire, brush, etc. Also, you should never let them touch the surface, since even the lightest contact with the surfaces may cause rust formation. You should use brushes made of polymer plastic or natural brushes or thin wire.



You should take care to move towards the smoothing direction, so that you will not scratch the surface. Finally, rinse with clean water and dry thoroughly.

We remind you that corrosion (rust formation) on stainless steel surfaces is not created by itself, but rather due to the use of improper cleaning aid (e.g. whitening or particularly caustic cleaning aid based on chlorine). Following a particular period of use, calcium sediments are formed in the internal walls of the dispenser (due to mineral particles in the water), which may affect the correct operation of the appliance. For this reason, regular removing of salt formations is required.

We recommend letting this work (removing of salt formations) to be performed by specialized personnel (or by an authorized local dealer who sold the appliance).

2.10 Customer service

If you face any problems during the use of your appliance, we kindly ask you to refer to our company (or to the authorized local dealer who sold the appliance).

2.11 Spare parts, Accessories and Components

All spare parts and components can be found in the authorized local dealer, who sold this appliance, or directly in our company.

In case of claims or complaints, you should necessarily report the model and serial number of the appliance / machine. These can be found on the label that is attached on the appliance.

Note 3 : Complete and send directly the Warranty Certificate.

2.12 Troubleshooting

PROBLEM	CAUSE	SOLUTION
The dishwasher does not operate properly	Connection interruption	Check the connection
	You have not turned the switch of the appliance ON	Turn the switch ON
	Main switch / or fuse has not been activated / or it is faulty	Check the main switch / or fuse
	The switch of the appliance is faulty	Refer to the authorized local dealer who sold the appliance or directly to the manufacturer
	The water inlet valve is faulty	
	The door is not closed	Close the door
	You have not turned the water supply on	Turn the supply on
The appliance operates, but the switch LED does not light on	The LED is faulty	Change the LED
Boiler heating does not operate	Switch or main switch or fuse has not been activated	Check the switch of the appliance and the main switch or fuse
	The safety thermostat of the boiler is faulty	Refer to the authorized local dealer or the manufacturer
	The 93 thermal fuse of the boiler is faulty	
	Pressure regulator is faulty	Refer to the authorized local dealer or the manufacturer
	"Boiler heating" relay is faulty	
Boiler fuse is burned out	Refer to the authorized local dealer or the manufacturer	
Boiler heating operates, but LED does not turn on	Faulty LED	Change LED
Dispenser heating does not operate	Switch N1 of the appliance or main switch or fuse has not been activated	Activate the corresponding switch or fuse
	Boiler heating is open	Wait
The 85 thermal fuse is faulty. The dispenser's fuse is burned out	The thermostat switch of 60 heating is faulty	Refer to the authorized local dealer or the manufacturer
	"Compartment heating" relay is faulty	
Dispenser's heating operates, but LED does not turn on	Faulty LED	Change LED
Pump motor does not operate	Main switch or fuse is not activated. The door is not closed.	Activate the main switch or fuse Close the door
	Main relay is faulty	Refer to the authorized local dealer or the manufacturer
	Pump motor is faulty	
	Program selection switch is faulty	
Motor operates, but pump does not rotate	An object has jammed the pump fin	Refer to the authorized local dealer or the manufacturer
	Salts or detergent have been petrified following non-operation of the appliance	Rotate the screw on the backside of the motor, until it rotates freely
Items do not dry (dishes, glasses, etc.)	Compartment has no drying aid	Insert drying aid to the compartment
	Drying valve is faulty	Refer to the authorized local dealer or the manufacturer
	Program switch is faulty	
	Rinsing arms do not rotate	
	Basket does not rotate	

RATINGS AND EXPECTATIONS

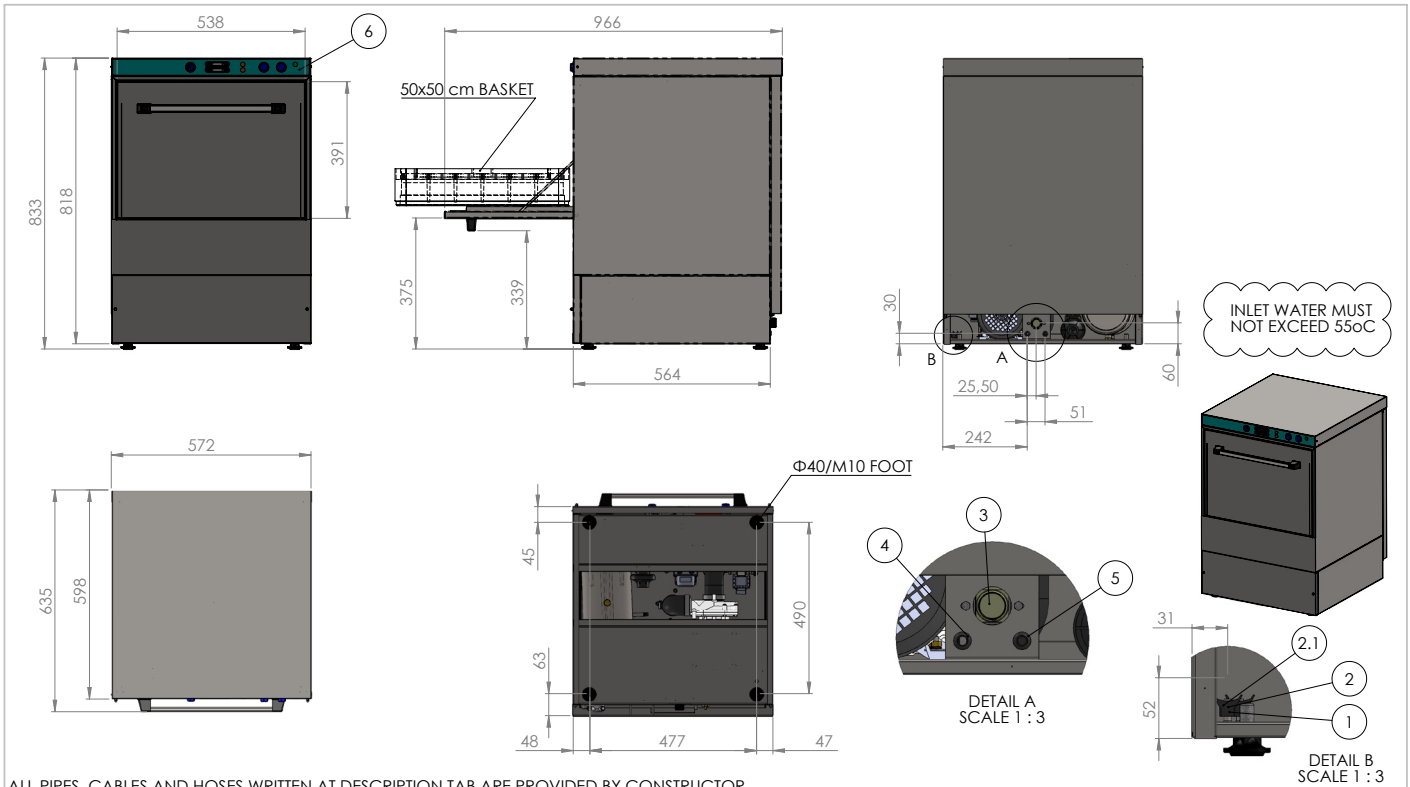

ALL PIPES, CABLES AND HOSES WRITTEN AT DESCRIPTION TAB ARE PROVIDED BY CONSTRUCTOR

Customer: Order Date: Or. Number:		MACHINE PROPERTIES							A/A	DESCRIPTION	BUBBLE INFORMATION	NOTE
Series Description:	UNDERCOUNTER	Capacity (LT)	Weight (KG)	Voltage (V)	Max. Amp./Phase	Max. Loading (KW)			1.	Electrical Supply Connection cable Pos.	PVC Coated H05 VVF 3 x 2,5mm, Cable Length = 2m	
Model Description:	EM-LV50								2.1	Draining Pipe (1,6m) Φ 28 Outer Φ 24 Inner Pos.	Used Only for Free Flow, Drainage Without Pump	
Model Version:	230 V	Boiler	Tub	Net	Gross	230V-1N-50/60Hz	15.6A	3.6	2.	Draining Pipe (1,6m) Φ 25 Outer Φ 20 Inner Pos.	Only With Draining Pump Included (Hman = 0,7m MAX)	
Drawing Code:	004.50.00009	6	35	55	60				3.	Inlet Male Nozzle Threaded End G3/4" for Water Supply	To Flexible Pipe Water Inlet Threaded Female Ends G 3/4" (Flexible Pipe Length = 1,5m)	
Drawing Date:	26/5/15								4.	Rinse Aid Flexible Pipe Pos. (Blue Color)	Outer Diameter Φ 6 x 1400mm Length	
Various Information:									5.	Detergent Flexible Pipe Pos. (Crystal Color)	Outer Diameter Φ 6 x 1400mm Length	
									6.	Control Panel		

ELECTRICAL DIAGRAM

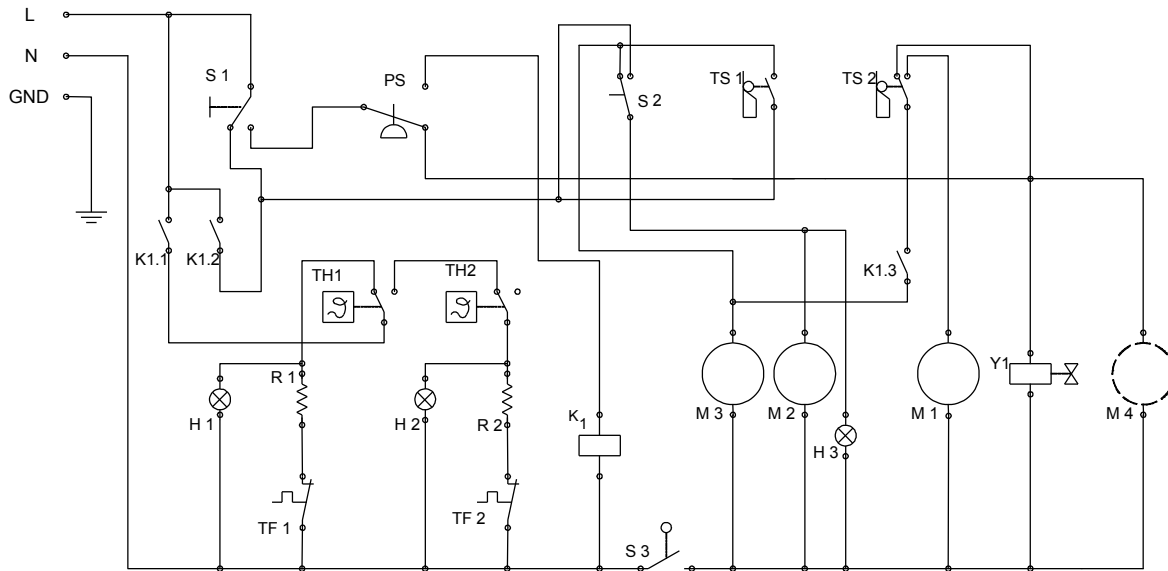

- | | |
|--|----------------------------|
| S 1 : Main switch | M 1 : Wash pump motor |
| S 2 : Start switch | M 2 : Timers motor |
| S 3 : Doors cut off switch | M 3 : Drainage pump motor |
| K 1 : Relay | M 4 : Detergent pump motor |
| R 1 : Boilers/Boosters heating element | TF : Thermofuse |
| R 2 : Tanks heating element | PS : Pressure switch |
| Y : Water inlet valve | TS : Timers microswitch |
| H : Indicator lamp | TH : Thermostat |

ELECTRICAL DIAGRAM

EM-LV50

220-240 Volt AC 50/60 Hz
Max 3600 W 15.6 A

INSTRUCTION MANUAL : EM-LV50-SP



EXPLODED VIEW AND SPARE PARTS LIST

ITEM NO.	PART NUMBER	DESCRIPTION	QTY.
2	001.50.00048	FRONT COVER INOX V50	1
3	001.50.00046	DOOR COMPLETE V50 - E50	1
4	001.00.00045	TERSON WASHER 5/12.2x8.8x2.3	2
6	001.00.00051	DOOR SNAP SET	2
7	001.00.00013	INOX SCREW M4x16	2
8	001.00.00117	DOOR NUT M4	2
9	002.00.00095	INOX NUT M4	2
10	002.00.00140	LOCK WASHER INOX Ø4	2
11	001.00.00014	SMALL BLACK LOCK V50	4
12	001.50.00043	BACK COVER INOX V50 - E50	1
13	001.00.00021	PLASTIC GUIDE FOR DOOR AXLE	2
14	001.00.00048-M	DOOR LEFT SUPPORT AXLE M4x50	1
15	001.00.00048	DOOR RIGHT SUPPORT AXLE M4x50	1
16	001.00.00110	DOMED CAP NUT M6	2
17	001.00.00023	INOX SCREW 2/8x10	4
20	001.50.00015	UPPER COVER INOX V50 - E50	1

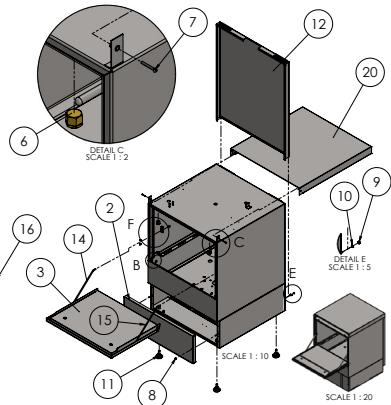

ITEM NO.	PART NUMBER	DESCRIPTION	QTY.
11	001.50.00011	BACK PART OF THE DOOR V-K	1
12	001.50.00027	FRONT PART OF THE DOOR V-K	1
3	001.00.00018	DOOR HANDLE COMPLETE V-K	1
4	002.00.00057	DOOR HANDLE PLASTIC FLANGE	2
10	003.00.00211	INOX COUNTERSUNK BOLT M8x30	2

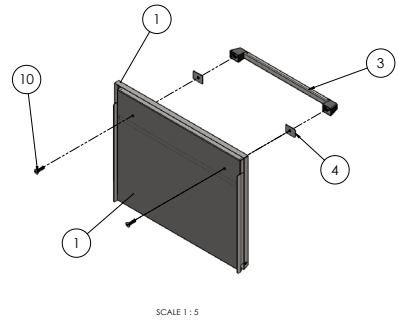

SERIES DESCRIPTION: UNDERCOUNTER	MODEL: EM-LV50	MODEL VERSION: 230V~N 50/60Hz	ITEM CODE: 004.50.00009	PAGE: 1	REVISION: 0	SERIES DESCRIPTION: UNDERCOUNTER	MODEL: EM-LV50	MODEL VERSION: 230V~N 50/60Hz	ITEM CODE: 001.50.00046	ITEM DESCRIPTION: DOOR COMPLETE V50 - K50	MODEL CODE: 004.15.00000	PAGE: 1	REVISION: 0
----------------------------------	----------------	-------------------------------	-------------------------	---------	-------------	----------------------------------	----------------	-------------------------------	-------------------------	---	--------------------------	---------	-------------

ITEM NO.	PART NUMBER	DESCRIPTION	VERGINA/QTY.
2	003.00.00094	CABLE PLASTIC CLAMP	2
3	002.00.00140	LOCK WASHER INOX Ø4	4
4	003.00.00046	NUT M4 (GALV)	4
5	003.50.00002	DISPLAY PANEL COMPLETE V50	1
6	004.50.00002	ELECTRICAL BOX COMPLETE 230V~N 50/60Hz	1

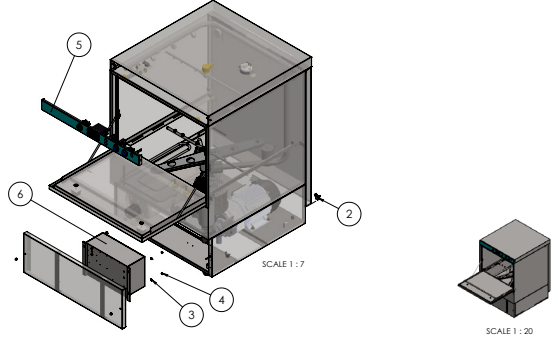

ITEM NO.	PART NUMBER	DESCRIPTION	QTY.
1	001.50.00004	SWITCH PANEL INOX V50	1
8	003.50.00009	MEMBRANE FOR THERMOMETER 250mm	2
3	003.00.00055	SWITCH START K25ND TWO CONTACTS	2
4	003.00.00564	INDICATOR ORANGE	2
5	003.00.00028	INDICATOR GREEN	1
6	003.00.00175	SWITCH ON-OFF ROUND 4 COND.	1
7	003.00.00563		

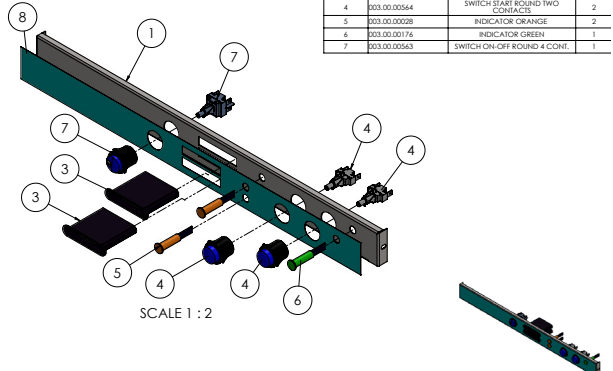

SERIES DESCRIPTION: UNDERCOUNTER	MODEL: EM-LV50	MODEL VERSION: 230V~N 50/60Hz	ITEM CODE: 003.50.00002	PAGE: 1	REVISION: 0	SERIES DESCRIPTION: UNDERCOUNTER	MODEL: EM-LV50	MODEL VERSION: 230V~N 50/60Hz	ITEM CODE: 004.50.00090	ITEM DESCRIPTION: DISPLAY PANEL COMPLETE V50	MODEL CODE: 004.50.00090	PAGE: 1	REVISION: 0
----------------------------------	----------------	-------------------------------	-------------------------	---------	-------------	----------------------------------	----------------	-------------------------------	-------------------------	--	--------------------------	---------	-------------

ITEM NO.	PART NUMBER	DESCRIPTION	QTY.
3	003.00.00092	POWER SUPPLY BOARD THREE COND.	1
4	003.00.00213	THERMOSTAT 0-90°C 150mm	2
5	001.00.00076	GALVANIZED MACHINE SCREW M6x8	4
6	003.00.00056	MAGNETIC CONTACTOR	1
7	003.00.00046	NUT M4 (GALV)	2
8	003.00.00048	WASHER 120 SEC. Q3-START	1
9	003.00.00278	GALV. BOLT M4x10	2

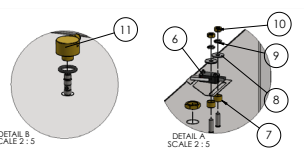
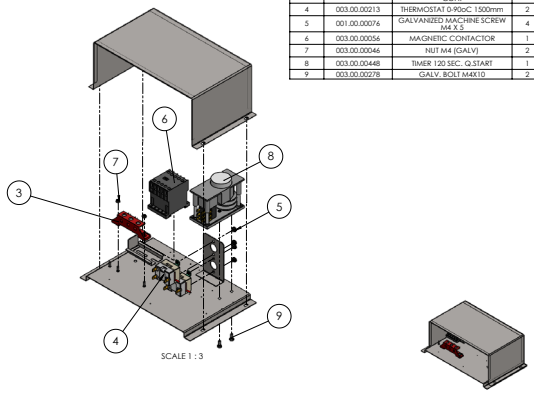

ITEM NO.	PART NUMBER	DESCRIPTION	VERGINA/QTY.
5	003.00.00231	DOOR SWITCH MECH. PART	1
6	003.00.00426	DOOR SWITCH EL. PART 35-40-50 COMPLETE	1
7	003.00.00085	SPACER FOR DOOR SWITCH	2
8	003.00.00216	WASHER STEEL Ø4x16	2
9	001.00.00024	GALVANIZED LOCK WASHER 6.4x1 (G)	2
10	003.00.00041	NUT M4 GALVANIZED	2
11	002.35.00029	UPPER RINGING BASE COMPLETE PRESSOSTAT	1
12	003.00.00033	TAPPING SCREW 3.5x9-30	1
13	002.30.00026	RINGING ARM UP OR DOWN V-K	2
26	002.30.00041	LOCK NUT FOR RINGING ARM	2

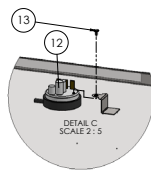
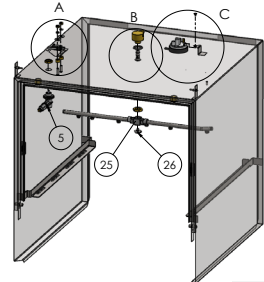

SERIES DESCRIPTION: UNDERCOUNTER	MODEL: EM-LV50	MODEL VERSION: VERGINA50 230V~N 50/60Hz	ITEM CODE: 004.50.00090	PAGE: 1	REVISION: 0	SERIES DESCRIPTION: UNDERCOUNTER	MODEL: EM-LV50	MODEL VERSION: 230V~N 50/60Hz	ITEM CODE: 004.50.00090	ITEM DESCRIPTION: MECHANICAL EQUIPMENT	MODEL CODE: 004.50.00090	PAGE: 3	REVISION: 0
----------------------------------	----------------	---	-------------------------	---------	-------------	----------------------------------	----------------	-------------------------------	-------------------------	--	--------------------------	---------	-------------

INSTRUCTION MANUAL : EM-LV50-SP

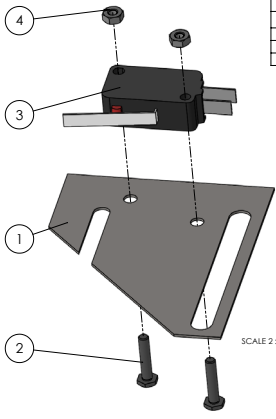

ITEM NO.	PART NUMBER	DESCRIPTION	VERGINA/QTY.
1	003.00.00077	BASE INOX FOR THE ELECTRICAL DOOR SWITCH	1
2	003.00.00045	GALV. HEX. BOLT M8X16	2
3	003.00.00089	DOOR MICRO SWITCH	1
4	002.00.00090	GALV. NUT M8	2

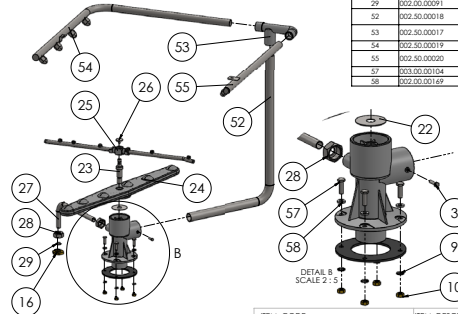

ITEM NO.	PART NUMBER	DESCRIPTION	VERGINA/QTY.
3	002.50.00038	WASHING BASE DOWN V-K COMPLETE	1
9	001.00.00044	SAEVANISED LOCK WASHER 8x11 NUT	4
10	003.00.00041	NUT M8 GALVANISED	4
16	002.50.00042	NUT 1/2"	1
22	002.50.00116	FLOW CONTROL COIL FOR BASE V-K	1
23	002.11.00002	AXLE INOX FOR BASE DOWN V300	1
24	002.50.00006	RINSING ARM UP OR DOWN V-K	2
25	002.50.00029	LOCK NUT FOR RINSING ARM	2
26	002.50.00046.1	RINSE PIPE RETAINING NUT	2
27	002.50.00022	RINSE PIPE INOX V-K	1
28	002.00.00144	RINSE PIPE RETAINING NUT	2
29	002.00.00091	ORING 38.1x33	2
30	002.50.00018	WASHING UPPER SYSTEM INOX SUPPLY PIPE	1
53	002.50.00017	CONNECTOR WASHING SYSTEM PLASTIC	1
54	002.50.00019	WASHING UPPER SYSTEM INOX UP-LEFT	1
55	002.50.00020	WASHING UPPER SYSTEM INOX UP-RIGHT	1
57	003.00.00104	INOX HEX BOLT M8X20	4
58	002.50.00149	TEFLON 12-B-2	4

ITEM CODE: 003.00.00426		ITEM DESCRIPTION: DOOR SWITCH ELECTRICAL PART COMPLETE		ITEM CODE:		ITEM DESCRIPTION: MECHANICAL EQUIPMENT	
SERIES DESCRIPTION: UNDERCOUNTER	MODEL DESCRIPTION: VES9	MODEL VERSION: 230V~N 50/60Hz	MODEL CODE:004.50.00009	PAGE:	REVISION:	SERIES DESCRIPTION: UNDERCOUNTER	MODEL: EM-LV50
						MODEL VERSION: 230V~N 50/60Hz	MODEL CODE:004.50.00090
						PAGE: 4	REVISION: 0

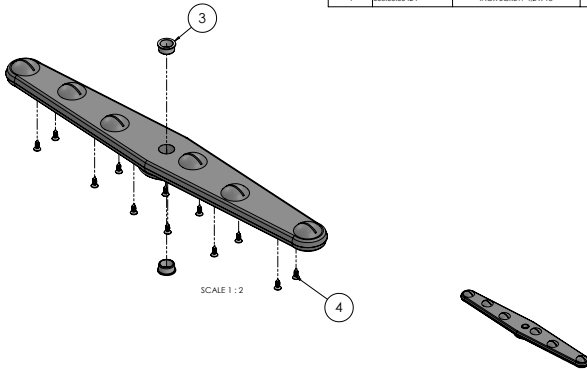

ITEM NO.	PART NUMBER	DESCRIPTION	QTY.
3	002.00.00029	TEFLON 52X210	2
4	003.00.00424	INOX SCREW 4.2 X 13	12

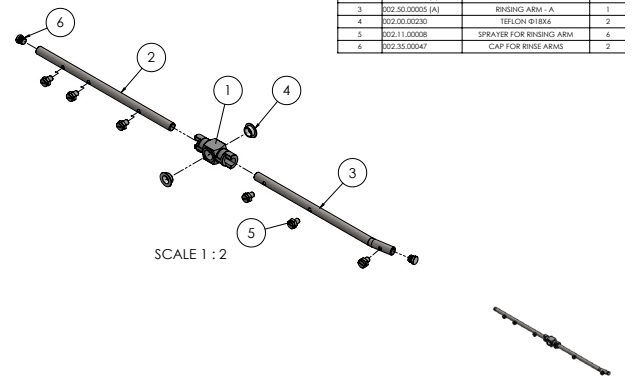

ITEM NO.	PART NUMBER	DESCRIPTION	QTY.
1	002.50.00005	PLASTIC BASE FOR RINSING ARM	1
2	002.50.00055 (B)	RINSING ARM SINGLE - B	1
3	002.50.00055 (A)	RINSING ARM - A	1
4	002.00.00230	TEFLON 918x6	2
5	002.11.00008	SPRAYER FOR RINSING ARM	6
6	002.35.00047	CAP FOR RINSE ARM	2

ITEM CODE: 002.50.00006		ITEM DESCRIPTION:		ITEM CODE: 002.50.00026		ITEM DESCRIPTION: RINSING ARM UP OR DOWN V-K	
SERIES DESCRIPTION: UNDERCOUNTER	MODEL DESCRIPTION: VES9	MODEL VERSION: 230V~N 50/60Hz	MODEL CODE:004.50.00090	PAGE: 1	REVISION: 0	SERIES DESCRIPTION: UNDERCOUNTER	MODEL: EM-LV50
						MODEL VERSION: VERGINA 50 230V~N 50/60Hz	MODEL CODE:004.50.00090
						PAGE: 1	REVISION: 0

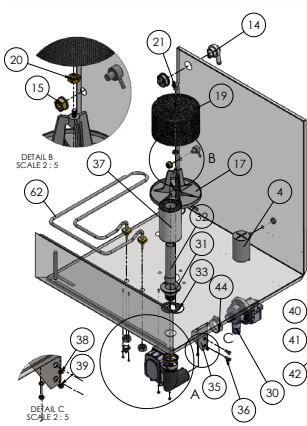

ITEM NO.	PART NUMBER	DESCRIPTION	VERGINA/QTY.
4	002.00.00074	PRESSOSTAT CHAMBER	1
14	002.00.00028	HEAT RESISTANT PLASTIC DOOR	1
15	002.00.00029	OVERSIGHT TANK INJECTION	1
17	002.00.00028	NOSE BASE FOR TANK FUSE V-K	1
19	002.50.00000	FILTER IN THE TANK FOR THE PUMP V-K	1
21	002.00.00028	HEAT RESISTANT	1
23	002.00.00017	FILTER RETAINING NUT	1
25	002.00.00186	TANK DRAINING PUMP 230V / 220V	1
31	002.00.00027	DRAIN AND OVERFLOW VALVE PLASTIC BASE	1
32	002.50.00023	DRAIN AND OVERFLOW VALVE PLASTIC PART NEW V-K	1
33	002.00.00026	SEWER GASCAP 10X55x1	1
34	002.00.00123	REFLECTOR INOX	1
35	001.50.00045	NOSE BASE FOR DRAINING PUMP V300	1
36	002.00.00065	NOSE BASE FOR DRAINING PUMP V-K	2
37	001.50.00040	DRAIN PUMP FILTER V300	1
38	002.00.00040	LOCK WASHER INOX 8x11	4
39	003.00.00046	NUT M8 GALVNI	4
40	002.00.00014	HEAT RESISTANT	2
41	002.00.00148	TANK THERMOSTAT FUSE	1
42	002.00.00090	GALV. HEX. BOLT	2
43	002.00.00019	DRAINING PUMP PART FOR V300	1
44	002.00.00049	CLAMP 25x6	2
44	003.00.00429	PERISTALTIC OVERSIGHT PUMP 1000 / 230V	1
42	002.50.00006	HEATER ELEMENT TANK 2.4 KW / 230V	1

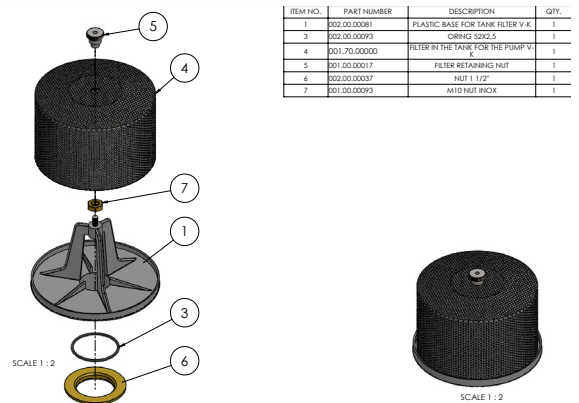

ITEM NO.	PART NUMBER	DESCRIPTION	QTY.
1	002.00.00081	PLASTIC BASE FOR TANK FILTER V-K	1
3	002.00.00093	ORING 52X2.5	1
4	001.70.00000	FILTER IN THE TANK FOR THE PUMP V-K	1
5	001.00.00017	FILTER RETAINING NUT	1
6	002.00.00037	NUT 1/2"	1
7	001.00.00093	M10 NUT INOX	1

ITEM CODE:		ITEM DESCRIPTION: MECHANICAL EQUIPMENT		ITEM CODE:		ITEM DESCRIPTION: TANK FILTER V-K COMPLETE	
SERIES DESCRIPTION: UNDERCOUNTER	MODEL DESCRIPTION: VES9	MODEL VERSION: 230V~N 50/60Hz	MODEL CODE:004.50.00090	PAGE: 1	REVISION: 0	SERIES DESCRIPTION: UNDERCOUNTER	MODEL: EM-LV50
						MODEL VERSION: 230V~N 50/60Hz	MODEL CODE:004.50.00090
						PAGE: 1	REVISION: 0

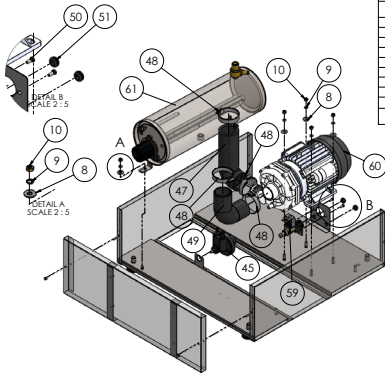

ITEM NO.	PART NUMBER	DESCRIPTION	VERGEM./QTY.
8	003.00.00516	WASHER STEEL Ø4x18	5
9	001.00.00204	GALVANIZED LOCK WASHER 6x11x0.7	5
10	003.00.00041	NUT M6 GALVANIZED	5
45	003.00.00268	HYDRAULIC RINSE AND PUMP	1
47	002.50.00392-1	WASH PUMP HOSE (OUTLET)	1
48	002.00.00020	CLAMP Ø6-Ø9	4
49	003.00.00127-1	WASH PUMP HOSE (INPUT)	1
50	003.00.00278	GALV. BOLT M6x10	2
51	003.00.00025	CABLE RUBBER PROTECTION	2
59	003.00.00331	WATER INPUT VALVE	1
60	003.00.00330	PUMP 0.75hp 50Hz 230V IP44	1
61	006.50.00001	BOILER COPPERE WITH HEATER ELEM. V500	1

ITEM NO.	PART NUMBER	DESCRIPTION	VERGEM./QTY.
1	001.50.00017	BOILER V500 Ø140x400	1
2	002.50.00001	OUTLET BASE BOILER V500	1
3	002.00.00076	BOILER DRAIN THREADED CAP	1
4	003.00.00260	BOILER ELEMENT FITTING BASE	1
5	003.50.00005	HEATER ELEM. BOILER 3kW / 230V / V.E.	1
6	003.00.00516	WASHER STEEL Ø4x18	3
7	003.00.00041	NUT M6 GALVANIZED	3
8	003.00.00180	BOILER THERMORUSE 10scC	1
9	002.00.00090	GALV. NUT M3	2
10	001.00.00204	GALVANIZED LOCK WASHER 6x11x0.7	3
11	003.00.00004	HEATER ELEMENT COVER	1

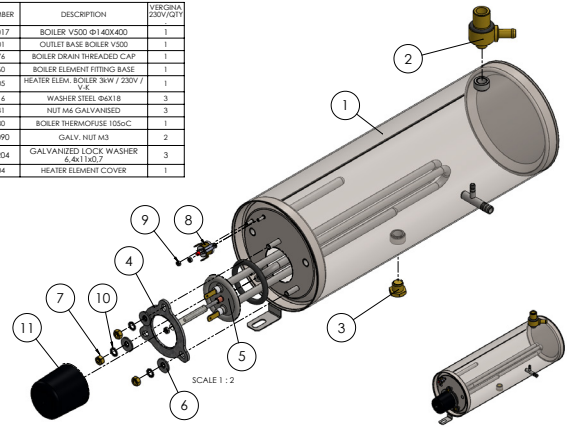

SERIES DESCRIPTION: UNDERCOUNTER	MODEL: EM-LV50	ITEM CODE: MODEL VERSION: 230V ~ N 50/60Hz	ITEM DESCRIPTION: MECHANICAL EQUIPMENT MODEL CODE:004.50.00090 PAGE: 2 REVISION: 0	SERIES DESCRIPTION: UNDERCOUNTER	MODEL: EM-LV50	ITEM CODE: 006.50.00001 MODEL VERSION: 230V ~ N 50/60Hz	ITEM DESCRIPTION: BOILER COMPLETE WITH HEATER ELEM. V500 MODEL CODE: 004.50.00090 PAGE: 1 REVISION: 0

STANDARDS AND DIRECTIVES

Meaning of crossed out wheeled dustbin:

Do not dispose of electrical appliances as unsorted municipal waste, use separate collection facilities.

Contact your local government for information regarding the collection systems available.

If electrical appliances are disposed of in landfills or dumps, hazardous substances can leak into the groundwater and get into the food chain, damaging your health and well-being.

When replacing old appliances with new ones, the retailer is legally obligated to take back your old appliance for disposals at least free of charge.

The device complies with current EU standards and directives. If necessary, we will send you the corresponding declaration of conformity.

Packaging disposal

Please separate the packaging materials accordingly and return them to the responsible collection points for recycling and environmental housing.



Device disposal

once the appliance has been used up, dispose of it properly at a collection point for electrical appliances. Electrical appliances do not belong in household waste.

Your responsible administration will inform you about the addresses and opening hours of collection points. This is the only way to ensure that old appliances are properly disposed of and recycled. Thank you very much!





CE